

# Estimation of Daily Global Solar Irradiation in Indonesia with Artificial Neural Network (ANN) Method

*by* Meita Rumbayan 7

---

**Submission date:** 13-Nov-2018 07:08AM (UTC+0700)

**Submission ID:** 1037763451

**File name:** ation\_in\_Indonesia\_with\_Artificial\_Neural\_Network\_ANN\_Method.pdf (1.62M)

**Word count:** 2301

**Character count:** 14402

# Estimation of Daily Global Solar Irradiation in Indonesia with Artificial Neural Network (ANN) Method

Meitarumbayan<sup>1</sup>, Ken Nagasaka<sup>1</sup>

<sup>1</sup>Department of Electronic and Electrical Engineering,  
Tokyo University of Agriculture and Technology  
Tokyo, Japan

E-mail: meitarumbayan@yahoo.com

**Abstract**—This paper demonstrates the use of neural network method for estimating daily global solar radiation in the horizontal surface by meteorological data in Indonesia. The database consists of 1826 daily measured data, in term of sunshine duration, average temperature, average relative humidity and global solar radiation. The data has been collected in Jakarta (altitude 6°15'S, longitude 106° 45'E), a city as capital of Indonesia. The 1461 daily measured data between 2005 and 2008 are used to train the neural networks while the data for 365 days in 2009 are used as testing data. The estimation of global solar irradiation were made using four combinations of proposed model of data sets namely: (i) day of the year, daily average relative humidity and daily average temperature as inputs, (ii) day of the year, daily average relative humidity and sunshine duration as inputs, (iii) day of the year, daily average temperature and sunshine duration as inputs, (iv) day of the year, daily average relative humidity, daily average temperature and daily sunshine duration as inputs. The output for the four combinations proposed model is daily average global solar irradiation. The comparison result show that the best model to estimate global solar irradiation is performed by (iii) and (iv) that obtain the Mean Average Percentage Error (MAPE) at below 10%.

**Keywords**— Solar irradiation; Artificial neural network; Multi-Layer Perceptron

## I. INTRODUCTION

Renewable energy such as solar energy system can be an alternative supply to the islands where are not connected to the grid. PV system can be used for electrification and it most suitable for remote and island area such as Indonesia in the term of resource availability and economic feasibility [1].

Solar irradiation data provide information on how much of the sun's energy strikes a surface at a location on earth during particular time period. The amount of solar irradiation in the particular location is important for solar energy system design, such as stand alone PV and hybrid system. Due to the utilization of solar energy potential in many areas, there is an increasing need for more precise modelling and prediction of solar irradiance.

The prediction of daily global solar irradiation is useful for development of solar energy devices as well as for their performances estimation. The knowledge of solar irradiation is important for planning the operations of power plant which converts solar energy into electricity. Study about solar irradiation prediction by using ANN with meteorological data in Indonesia has not yet been developed. The purposes of this study are defined as follow:

- To confirm the ability of the ANN to estimate global daily solar irradiation value in the island area of Indonesia
- To compare the result of proposed model by varying measured meteorological data as the input combination for solar irradiation estimation.

This paper is organized as follows: literature review about ANN theory and previous works on predicting solar irradiation are described in section 2. The database used in this study and the method of ANN application for predicting solar irradiations are presented in section 3. The result of simulation ANN model and evaluation is discussed in section 4. Conclusion is given in section 5.

## II. LITERATURE REVIEW AND PREVIOUS WORK

This section describes about literature review and previous works on predicting solar radiation by using ANN approach.

Artificial Neural Networks are computational systems that their model and functionality is inherit from the recently acquired knowledge of the biological computational units, namely, the brain's neurons. An ANN consists of many interconnected identical neurons. A typical neural network usually has 3 layers of neurons, each of which is connected to the neurons in the next layer. These connections are weights which are applied to values passed from one neuron to the next. Input values in the first layer are weighted and passed to the second (hidden layer). Neuron in the hidden layer produce outputs that are based upon the sum of weighted values passed to them. The hidden layer passes values to the output layer in the same fashion and the output layer produces the desired result. The network learns by adjusting the interconnection weights. The answers the network is producing are repeatedly compared with the correct answers, and each time the connection weights are adjusted in the direction of the correct answers [2].

The typical of neural networks that consists of input layer, hidden layer and output layer is shown in figure 1.

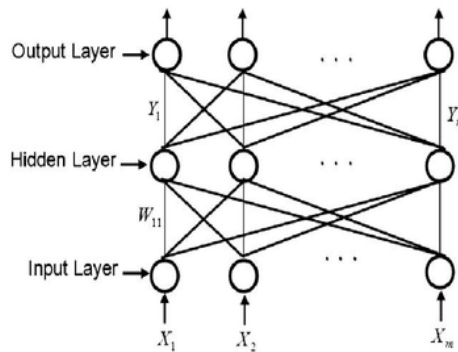

Fig. 1 A typical Multi-Layer Perceptron ANN structure

Basically there are three parameter in the ANN, i.e. learning rate, momentum rate and weight. Learning rate term,  $L$ , indicates how much the weight change to effect on each pass. This is typically a number between 0 and 1. Momentum term,  $M$ , indicates how much a previous weight change should influence the current weight change. As neuron pass values from one layer of the network to the next layer, the values are modified by a weight value in the link that represents connection strengths between the neuron. The weights of connection between neurons are adjusted during

the training process to achieve the desired input and output relation of the network. ANNs perform in many different forms, some require model with total interconnection among neurons in many layers [3]. One of the typical one is Back Propagation (BP). The Back Propagation (BP) algorithm is a supervised iterative training method for feed forward nets with a differential nonlinear function. The BP algorithm minimizes the mean square difference between the network output and the desired output.

The advantages of neural networks are their learning ability to perform specific tasks. Learning is accomplished by adjusting the weights of the connections between neurons. The network learns the connection weights from the available representing training data. One of the training paradigms is the supervised learning, where the network is provided with a correct input for every input pattern during training. Weights are adjusted so that the network can produce the outputs as close as possible to the known correct answers. During the learning phase, the network captures the underlying rule for associating the inputs with the desired output. Due to the generalization capabilities of the networks, it performs similarly on data that have not been used for training [4].

There are several studies to predict solar irradiation potential based on ANN approach. Since ANN are highly non linear and require no prior assumption concerning the data relationship, they have become useful tool for predicting solar irradiation. ANN models have been successfully demonstrated to have potential in predicting solar irradiation by many researchers.

The ANNs (multilayer perceptions type) were trained to estimate global solar irradiation as a function of the maximum and minimum air temperature and extraterrestrial radiation. In order to consider the effect of each meteorological variable on daily global solar irradiation predictions, Behrang et al. [5] used combination of the measured data namely day of the year, daily mean air temperature, relative humidity, sunshine duration, evaporation and wind speed using ANN techniques. The predicted values of best ANN model have a MAPE about 5.21% for Dezful city in Iran.

Rehman and Mohandes trained air temperature, number of days and relative humidity as inputs to neural networks in order to estimate daily global solar irradiation for Abba city in Saudi Arabia. Result showed a mean absolute percentage error of 4.49% [6].

All these models are location dependent. There is a few research on solar radiation prediction in Indonesia. So far, there is no report about solar radiation prediction for Indonesia by using ANN method. The present study explores the comparison of different proposed model using data set combination of measured meteorological data to predict global solar irradiation by using ANN method.

## III. DATA AND DEVELOPED MODEL OF ANN

This section is described about database used in this study and the method of ANN application for predicting global daily solar irradiation in Jakarta, Indonesia. As case study, Jakarta, a city situated in the Java island was chosen

to represent meteorological data measurement for train in the ANN based. The data is taken from meteorological station in Pondok Beach, Jakarta which is situated at altitude 6°15' S, longitude 106° 45' and all meteorological data is measured with a Campbell-Stokes heliograph and solar radiation was recorded manually by Sun Beam pyranometer. No information is available regarding instrument calibration and other possible error during measurement.

Jakarta is located on the northwest coast of Java. Jakarta has a hot and humid tropical wet and dry climate. Wet seasons in Jakarta cover the majority of the year, running from November through June. The remaining four months forms the city's dry season. The average temperature is 27.7 and average relative humidity is 80.5% over the year. Jakarta's weather is affected by 2975 hours of sunshine per year which is an average of 8.15 hours per day.

The data of daily global solar irradiation during January 2005 to December 2009 (5 years) were used to estimate global solar irradiation by ANN model. The database consists of 1826 days of data. The days with inadequate data were removed from the database. Data were split into two, as four years (2005 to 2008) were used for training a neural network and the rest data for testing. For testing, the one year data (2009) were used for evaluating predicted network data by comparing to the actual measured values. Training the model was done using a neural net simulator known as "NeuroShell."

The training starts with defining the parameters with minimum error by trial and error using fixed and change parameter one by one, then use selected parameter in neural network for several case of the number of neurons in the hidden layer. Then the model of ANN was used for training and testing.

In order to consider the effect of combination meteorological variable on daily global solar irradiation estimation, four following model of input variables are proposed:

- (i) day of the year, daily average relative humidity and daily average temperature as inputs,
- (ii) day of the year, daily average relative humidity and sunshine duration as inputs,
- (iii) day of the year, daily average temperature and sunshine duration as inputs,
- (iv) day of the year, daily average relative humidity, daily average temperature and daily sunshine duration as inputs.

By using ANN model, the result of solar irradiation has been identified, then it has been compared with the actual measured of meteorological data. Predicted values of global solar irradiation were compared with measured values taken from meteorological data through analysis of error, in terms of Mean Absolute Percentage Error (MAPE).

The mean absolute percentage error (MAPE) is defined by equation 1.

$$MAPE = \sum | (H_{mi} - H_{pi}) / H_{mi} | / n \quad (1)$$

where  $H_{mi}$  is measured values and  $H_{pi}$  is predicted values for monthly average global solar irradiation,  $n$  is the number of testing examples.

In MAPE, sign of errors are neglected and percentage errors are added up to obtain the average. MAPE is commonly used in quantitative forecasting methods because it produces a measure of relative overall fit. It usually expresses accuracy as a percentage.

This section presents the results of simulation ANN model of proposed combination model with the same input data in the four combinations. The evaluation is done by comparing the measured irradiation value and estimated irradiation values by neural network based on statistical error.

Comparison between measured and estimated values of global solar irradiation for testing data based on the four models (meteorological data combination variable as inputs) has been shown in Figure 2(a), 2(b), 2(c), 2(d).

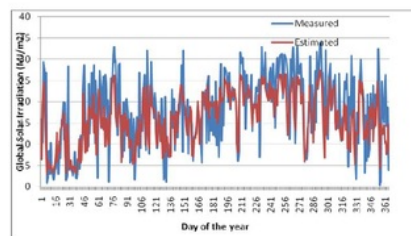

2(a)

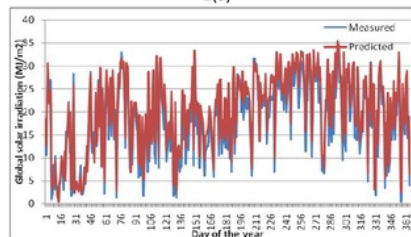

2(b)

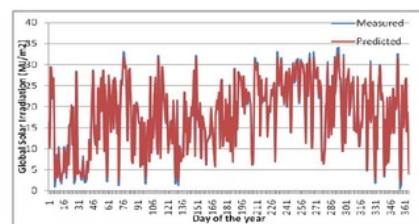

2(c)

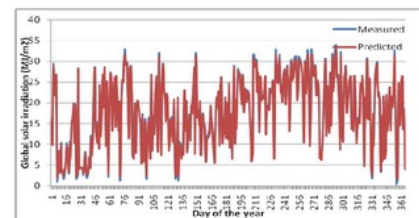

2(d)

Fig. 2. Measured and estimated values comparison based on MLP network for (a) MLP-i, (b) MLP-ii, (c) MLP-iii and (d) MLP-iv

Statistical errors for 4 combinations of variable meteorological data that train in ANN were evaluated in this study. The evaluation of measured and predicted values for 4 combinations model was presented in Table I.



TABLE I  
STATISTICAL ERROR FOR 4 COMBINATIONS OF VARIABLE METEOROLOGICAL DATA

Combination model	MAPE (%)
1	50.4
2	20.5
3	6.1
4	5.4

#### V. CONCLUSIONS

This study has been proposed four combinations model of ANN to predict daily global solar irradiation in horizontal surface in Jakarta, Indonesia as area of study. This study proves that ANN can be use for global solar irradiation estimation in Jakarta, Indonesia by using meteorological data.

The ANN predicts solar irradiation with a mean absolute percentage error 50.4%, 20.5%, 6.1% and 5.4% are performed by the (i), (ii), (iii) and (iv) respectively. In this paper, an accuracy of 90% and a mean absolute percentage error at below 10% as the best result can be obtained by model (iii) and (iv).

It should be noted that the sunshine duration, average temperature and relative humidity play important parameter for estimating global solar irradiation. Concept of ANN global solar irradiation in this location which is dealing with meteorological data. It can open wide analyses to other location in island area of for future work.

#### ACKNOWLEDGMENT

We would like to thank Meteorological and Climate Biro of Indonesia for providing the data.

#### REFERENCES

- [1] M. Rumbayan and K. Nagasaka, "Resource and Economic Assessment of Solar Irradiation Potential in an Island Community" in *Proc. IJISS*, 2010, paper 02A33, p. 59.
- [2] "Manual User Book," Neuroshell 2, Ward Systems Group, 1993.
- [3] B. Kermanshahi, *Design and Application of Neural Networks*. Shokodo Publishing Company, June 1999.
- [4] M. Mohandes, M.S Rehman and T.O Halawani, "Estimation of Global Solar Radiation Using Artificial Neural Networks," *Renewable Energy*, vol. 14, pp. 179-184, 1998.
- [5] M. A. Behrang, E. Assareh, A. Ghanbarzadeh, A. R. Noghrehabadi, "The potential of different artificial neural network (ANN) techniques in daily global solar radiation modeling based on meteorological data," *Soalr Energy*, vol. 84, pp. 1468-1480, 2010.
- [6] S. Rehman and M. Mohandes, "Artificial neural network estimation of global solar radiation using air temperature and relative humidity," *Energy Policy*, vol. 36, pp. 571-576, 2008.

# Estimation of Daily Global Solar Irradiation in Indonesia with Artificial Neural Network (ANN) Method

---

## ORIGINALITY REPORT

---

25%

SIMILARITY INDEX

9%

INTERNET SOURCES

24%

PUBLICATIONS

%

STUDENT PAPERS

---

## PRIMARY SOURCES

---

1

"Ask the Weather Guys: Did we have a normal winter this year?", UWIRE Text, March 14 2016 Issue

Publication

2%

---

2

Jiang, Y.. "Prediction of monthly mean daily diffuse solar radiation using artificial neural networks and comparison with other empirical models", Energy Policy, 200810

Publication

2%

---

3

Rizkalla, Névine, and Patrice Hildgen. "Artificial Neural Networks: Comparison of Two Programs for Modeling a Process of Nanoparticle Preparation", Drug Development and Industrial Pharmacy, 2005.

Publication

2%

---

4

Benghanem, M.. "ANN-based modelling and estimation of daily global solar radiation data: A case study", Energy Conversion and Management, 200907

Publication

2%

---

5	Mahmoud, M.A.. "Architecture and performance of neural networks for efficient A/C control in buildings", Energy Conversion and Management, 200312	1%
Publication		
6	Tymvios, F.S.. "Comparative study of Angstrom's and artificial neural networks' methodologies in estimating global solar radiation", Solar Energy, 200506	1%
Publication		
7	"Computational Intelligence in Data Mining - Volume 3", Springer Nature America, Inc, 2015	1%
Publication		
8	<a href="http://www.opentalkz.com">www.opentalkz.com</a>	1%
Internet Source		
9	Bhardwaj, Saurabh, Vikrant Sharma, Smriti Srivastava, O.S. Sastry, B. Bandyopadhyay, S.S. Chandel, and J.R.P. Gupta. "Estimation of solar radiation using a combination of Hidden Markov Model and generalized Fuzzy model", Solar Energy, 2013.	1%
Publication		
10	Charles Teye Amoatey, Yaa Asabea Ameyaw, Ebenezer Adaku, Samuel Famiyeh. "Analysing delay causes and effects in Ghanaian state housing construction projects", International Journal of Managing Projects in Business, 2015	1%

11 Sthitapragyan Mohanty, Prashanta Kumar Patra, Sudhansu Sekhar Sahoo. "Prediction of global solar radiation using nonlinear auto regressive network with exogenous inputs (narx)", 2015 39th National Systems Conference (NSC), 2015 1%

Publication

---

12 Mehmet Bilgili. "Daily total global solar radiation modeling from several meteorological data", Meteorology and Atmospheric Physics, 04/11/2011 1%

Publication

---

13 Khalid Anwar, Sandip Deshmukh. "Use of Artificial Neural Networks for Prediction of Solar Energy Potential in Southern States of India", 2018 2nd International Conference on Green Energy and Applications (ICGEA), 2018 1%

Publication

---

14 [www.jitbm.com](http://www.jitbm.com) 1%  
Internet Source

---

15 [www.ijesd.org](http://www.ijesd.org) 1%  
Internet Source

---

16 Kutlu, Y.. "Optimizing the performance of an MLP classifier for the automatic detection of epileptic spikes", Expert Systems With 1%



## Applications, 200905

Publication

---

17

Renno, C., F. Petito, and A. Gatto. "ANN model for predicting the direct normal irradiance and the global radiation for a solar application to a residential building", *Journal of Cleaner Production*, 2016.

Publication

---

1%

18

[www.acisinternational.org](http://www.acisinternational.org)

Internet Source

---

1%

19

Belaid, S., and A. Mellit. "Prediction of daily and mean monthly global solar radiation using support vector machine in an arid climate", *Energy Conversion and Management*, 2016.

Publication

---

1%

20

Garijo, N., J. Martínez, J.M. García-Aznar, and M.A. Pérez. "Computational evaluation of different numerical tools for the prediction of proximal femur loads from bone morphology", *Computer Methods in Applied Mechanics and Engineering*, 2013.

Publication

---

1%

21

Yang, Xiaolin, Wangsheng Gao, Quanhong Shi, Fu Chen, and Qingquan Chu. "Impact of climate change on the water requirement of summer maize in the Huang-Huai-Hai farming region", *Agricultural Water Management*, 2013.

1%

22 [www.utdallas.edu](http://www.utdallas.edu) 1 %  
Internet Source

---

23 [technology.karabuk.edu.tr](http://technology.karabuk.edu.tr) <1 %  
Internet Source

---

24 [xxx.unizar.es](http://xxx.unizar.es) <1 %  
Internet Source

---

25 [www.eurasip.org](http://www.eurasip.org) <1 %  
Internet Source

---

26 Jiang, Y.. "Computation of monthly mean daily global solar radiation in China using artificial neural networks and comparison with other empirical models", Energy, 200909  
Publication <1 %

---

27 Altan Dombayci, O.. "Daily means ambient temperature prediction using artificial neural network method: A case study of Turkey", Renewable Energy, 200904  
Publication <1 %

---

28 Zhe, Wang, Wang Fei, Mi Zengqiang, and Liu Liqing. "Regression-based modeling methods for solar radiant exposure", 2011 International Conference on Mechatronic Science Electric Engineering and Computer (MEC), 2011.  
Publication <1 %

---

Moreno, A.. "Mapping daily global solar

29	irradiation over Spain: A comparative study of selected approaches", Solar Energy, 201109	<1%
Publication		
30	Khatib, Tamer, Azah Mohamed, K. Sopian, and M. Mahmoud. "Solar Energy Prediction for Malaysia Using Artificial Neural Networks", International Journal of Photoenergy, 2012.	<1%
Publication		
31	Elminir, H.K.. "Estimation of solar radiation components incident on Helwan site using neural networks", Solar Energy, 200509	<1%
Publication		
32	Ali H. Assi, Maitha H. Al Shamisi, Hassan A.N. Hejase. "MATLAB tool for predicting the global solar radiation in UAE", 2012 International Conference on Renewable Energies for Developing Countries (REDEC), 2012	<1%
Publication		

Exclude quotes  On

Exclude matches  Off

Exclude bibliography  On

LEMBAR  
HASIL PENILAIAN SEJAWAT SEBIDANG ATAU *PEER REVIEW*  
KARYA ILMIAH : JURNAL ILMIAH

Judul Karya Ilmiah (artikel) : Estimation of Daily Global Solar Irradiation in Indonesia with Artificial Neural Network (ANN) Method, International Journal on Advanced Science, Engineering and Information

Nama Penulis : Meita Rumbayan, Ken Nagasaka

Jumlah Penulis : 2

Status Pengusul : Penulis pertama

Identitas Jurnal Ilmiah : a. Nama Jurnal : International Journal on Advanced Science, Engineering and Information

b. Nomor ISSN : 978-983-42366-4-9

c. Volume, Nomor, Bulan Tahun : 1, 2, 2011

d. Penerbit : <http://ijaseit.insightsociety.org>

e. DOI artikel (jika ada) : 10.18517/ijaseit.1.2.40

f. Alamat web Jurnal : <http://ijaseit.insightsociety.org/>

g. Terindeks di DOAJ, Google Search

Kategori Publikasi Jurnal Ilmiah (beri  $\surd$  pada kategori yang tepat)

- Jurnal Ilmiah Internasional/Internasional bereputasi\*
- Jurnal Ilmiah Nasional Terakreditasi
- Jurnal Ilmiah Nasional/Nasional terindeks di DOAJ, CABI, COPERNICUS \*

Hasil Penilaian *Peer Review* :

Komponen yang dinilai	Nilai Maksimal Jurnal Ilmiah			Nilai Akhir yang Diperoleh
	International/International Bereputasi*	Nasional Terakreditasi	Nasional	
a. Kelengkapan unsur isi artikel (10%)	85			85
b. Ruang lingkup dan kedalaman pembahasan (30%)	80			29
c. Kecukupan dan kemutakhiran data /informasi dan metodologi (30%)	80			24
d. Kelengkapan unsur dan kualitas terbitan/jurnal (30%)	80			24
Total = 100%				80.5
Nilai Pengusul				80.5

Catatan penilaian artikel oleh Reviewer :

*tdk. Scopus*

Manado, November 2018

Reviewer,



Prof. Dr. Ir. Fabian J. Manoppo, M.Agr

NIP. 196210141992031001

Unit kerja : Fakultas Teknik Universitas Sam Ratulangi

**HASIL PENILAIAN SEJAWAT SEBIDANG ATAU PEER REVIEW  
KARYA ILMIAH : JURNAL ILMIAH**

Judul Jurnal Ilmiah (Artikel) : Estimation of Daily Global Solar Irradiation in Indonesia with Artificial Neural Network (ANN) Method, International Journal on Advanced Science, Engineering and Information

Penulis Jurnal Ilmiah : Meita Rumbayan, Ken Nagasaka

Identitas Jurnal Ilmiah : a. Nama Jurnal : International Journal on Advanced Science, Engineering and Information (ISSN 978-983-42366-4-9)  
DOI:10.18517/ijaseit.1.2.40  
b. Volume / Nomor : 1/2  
c. Edisi (bulan/tahun) : 2011  
d. Penerbit : <http://ijaseit.insightsociety.org>  
e. Jumlah halaman : 8 Halaman

Kategori Publikasi Jurnal Ilmiah :  Jurnal Ilmiah Internasional  
(beri ✓ pada kategori yang tepat)  Jurnal Ilmiah Nasional Terakreditasi  
 Jurnal Ilmiah Nasional Tidak Terakreditasi

Hasil Penilaian *Peer Review* :

Komponen Yang Dinilai	Nilai Maksimal Jurnal Ilmiah			Nilai Akhir Yang Diperoleh
	Internasional <input checked="" type="checkbox"/>	Nasional Terakreditasi <input type="checkbox"/>	Nasional Tidak Terakreditasi <input type="checkbox"/>	
e. Kelengkapan unsur isi buku (10%)	88			
f. Ruang lingkup dan kedalaman pembahasan (30%)	92			
g. Kecukupan dan kemutahiran data/informasi dan metodologi (30%)	90			
h. Kelengkapan unsur dan kualitas penerbit (30%)	90			
<b>Total = (100%)</b>				

Malang, November 2017

Reviewer

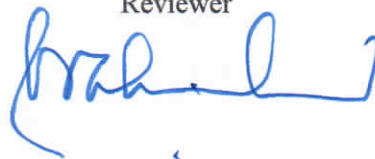

Prof. Dr. Eng. Ir. Abraham Lomi, MSEE, MIET, SMIEEE  
NIP.Y. 1018500108  
Unit kerja : Jurusan Teknik Elektro  
Institut Teknologi Nasional Malang

LEMBAR  
HASIL PENILAIAN SEJAWAT SEBIDANG ATAU *PEER REVIEW*  
KARYA ILMIAH : JURNAL ILMIAH

Judul Karya Ilmiah (artikel) : Estimation of Daily Global Solar Irradiation in Indonesia with Artificial Neural Network (ANN) Method, International Journal on Advanced Science, Engineering and Information

Nama Penulis : Meita Rumbayan, Ken Nagasaka

Jumlah Penulis : 2

Status Pengusul : Penulis pertama

Identitas Jurnal Ilmiah : a. Nama Jurnal : International Journal on Advanced Science, Engineering and Information

b. Nomor ISSN : 978-983-42366-4-9

c. Volume, Nomor, Bulan Tahun : 1, 2, 2011

d. Penerbit : <http://ijaseit.insightsociety.org>

e. DOI artikel (jika ada) : 10.18517/ijaseit.1.2.40

f. Alamat web Jurnal : <http://ijaseit.insightsociety.org/>

g. Terindeks di DOAJ, Google Search

Kategori Publikasi Jurnal Ilmiah (beri v pada kategori yang tepat)

- Jurnal Ilmiah Internasional/Internasional bereputasi\*
- Jurnal Ilmiah Nasional Terakreditasi
- Jurnal Ilmiah Nasional/Nasional terindeks di DOAJ, CABI, COPERNICUS \*

Hasil Penilaian *Peer Review* :

Komponen yang dinilai	Nilai Maksimal Jurnal Ilmiah			Nilai Akhir yang Diperoleh
	International/Internasional Bereputasi* <input checked="" type="checkbox"/>	Nasional Terakreditasi	Nasional	
a. Kelengkapan unsur isi artikel (10%)	80			8
b. Ruang lingkup dan kedalaman pembahasan (30%)	85			25,5
c. Kecukupan dan kemitakhiran data /informasi dan metodologi (30%)	90			27
d. Kelengkapan unsur dan kualitas terbitan/jurnal (30%)	80			24
Total = 100%				
Nilai Pengusul				84,5

Catatan penilaian artikel oleh Reviewer :

*Artikel menarik.*

Manado, 30 November 2017

Reviewer 2



Prof. Dr. Ir. Jeffrey I. Kindangen, DEA  
NIP. 196506031990031003  
Unit kerja : Fakultas Teknik

LEMBAR (FORM)  
 HASIL PENILAIAN SEJAWAT SEBIDANG ATAU PEER REVIEW  
 KARYA ILMIAH : JURNAL ILMIAH (JOURNAL)

Judul Karya Ilmiah (artikel) : Estimation of Daily Global Solar Irradiation in Indonesia with Artificial  
 (Title) Neural Network (ANN) Method, International Journal on Advanced  
 Science, Engineering and Information

Nama Penulis : Meita Rumbayan, Ken Nagasaka

Jumlah Penulis : 2

Status Pengusul : Penulis pertama

Identitas Jurnal Ilmiah : a. Nama Jurnal : International Journal on Advanced  
 Science, Engineering and  
 Information

b. Nomor ISSN : 978-983-42366-4-9

c. Volume, Nomor, Bulan Tahun : 1, 2, 2011

d. Penerbit : http://ijaseit.insightsociety.org

e. DOI artikel (jika ada) : 10.18517/ijaseit.1.2.40

f. Alamat web Jurnal : http://ijaseit.insightsociety.org/

g. Terindeks di DOAJ, Google Search

Kategori Publikasi Jurnal Ilmiah (beri v pada kategori yang tepat)

- Jurnal Ilmiah Internasional/Internasional bereputasi\*
- Jurnal Ilmiah Nasional Terakreditasi
- Jurnal Ilmiah Nasional/Nasional terindeks di DOAJ, CABI, COPERNICUS \*

Hasil Penilaian Peer Review :

Komponen yang dinilai	Nilai Maksimal Jurnal Ilmiah			Nilai Akhir yang Diperoleh
	International/International Bereputasi*	Nasional Terakreditasi	Nasional	
a. Kelengkapan unsur isi artikel (10%)/ <i>Completeness of the content</i>	85			8,5
b. Ruang lingkup dan kedalaman pembahasan (30%)/ <i>The Scope and the depth of discussion</i>	85			25,5
c. Kecukupan dan kemutakhiran data /informasi dan metodologi (30%)	85			25,5
d. Kelengkapan unsur dan kualitas terbitan/jurnal (30%)	85			25,5
Total = 100%				85
Nilai Pengusul				

Catatan penilaian artikel oleh Reviewer /Note by reviewer :

The idea of this paper is interesting. Very good.

6

Tokyo, March 2018

K. Nagasaka 

Prof. Dr. Ken Nagasaka

Department of Electrical and Electronic Engineering