

Perbaikan dari Author:

Morphometric and genetic variations of species composers of nike fish assemblages in Gorontalo Bay Waters, Indonesia

Abstract. Nike is Gobioid fish identified at the post-larval and juvenile stages whose habitat is still in the water of seawater before they migrate to the fresh-water, grow up, and spawn to fulfill their life cycle as an amphidromous species. This fish is very popular, favored by people, and has become an important economic commodity in Gorontalo. One of the biggest Nike fishing locations is Gorontalo Bay. This is very important to explore the types of species composing the Nike fish clusters in their contribution to fish biodiversity. Accordingly, This study aims to identify the species composers of Nike fish in Gorontalo Bay waters based on their morphometric and molecular characters. 2,523 samples were collected from the catches of fishermen's catches during three periods of their appearance in Gorontalo Bay waters to the estuary areas of Bone Bolango River from January to March 2019. The samples were then grouped based on their similarity of melanophore patterns, and morphometric characters of 10 units were then measured. This study found 20 different groups of melanophore patterns; 15 of them were new melanophore patterns. DNA samples from each group of new melanophore patterns were then isolated for molecular analysis. The data of morphometric characters were analyzed for its differentiators, while the DNA was analyzed using BLAST (Basic Local Alignment Search Tools) from NCBI. The results of morphometric analysis grouped the 20 melanophore patterns into three-four separate clusters that were confirmed through molecular analysis. The results of Gen Cytochrome Oxidase I (COI) sequences of mitochondrial DNA indicate that the new melanophore patterns of Nike fish clusters-assemblages in Gorontalo Bay waters have a high level of diversity with the discovery of consisting of six species; five species in the Gobiidae family (i.e. *Sicyopterus parvei*, *S. cynocephalus*, *S. longifilis*, *S. lagocephalus*, and *Stiphodon semoni*) generated Gobiidae family and a species in the Eleotridae family (*Belobranchus belobranchus*), species generated from Eleotridae family. It completes the data of the diversity of Nike fish composers in Gorontalo Bay waters which is very significant as the reference for inventoring and identifying the types of Nike fish in other estuary areas and adult amphidromous Gobies in Gorontalo rivers.

Keywords: amphidromous, COI gene, Gobies, Nike fish, morphometric, molecular

Abbreviations: Basic Local Alignment Search Tools (BLAST), Cytochrome Oxidase I (COI), Deoxyribonucleic acid (DNA), Polymerase Chain Reaction (PCR)

Running title: Morphometric and genetic variations of Species Composers of Nike Fish Assemblages

INTRODUCTION

Nike fish is a group of small Gobies that seasonally appear in Gorontalo Bay waters, usually at the end of the month in Hijri calendar in the last quarter moon phase towards the new moon. The people of Gorontalo catch this fish for consumption as well as in other areas, such as *penja* in West Sulawesi (Nurjirana, Burhanuddin, et al., 2019a; Nurjirana, Haris et al., 2019b) and *dulang* by the Philippines (Thomas et al., 2013). As a group of amphidromous fish, the catching is usually done when they migrate from the sea to the river. Keith (2003); Yamasaki et al. (2011); Taillebois et al. (2012); & Mennesson et al. (2019) mention that adult amphidromous fish will spawn in fresh-water, the eggs are placed on the substrate at the bottom of the water, and the larvae are then carried away by the estuary area into the sea. After the larvae live in the sea, they will then return to the

river at the post-larval and juvenile stages. Ollie et al. (2017); and Pasingi and Abdullah (2018) report that Nike fish in Gorontalo Bay will first appear in the sea and move closer to the estuary areas by time until they finally disappear.

The local communities and general public believe Nike fish as a single species. Several morphological and molecular characters-based studies were then conducted to prove their truth. Usman (2016) reported that Gorontalo Nike fish has been identified as *Awaous melanocephalus* Bleeker 1849.

Furthermore, Ollie et al. (2019) reported that Nike fish in the waters of Gorontalo Bay are *Sicyopterus longifilis* de Beaufort 1912. Meanwhile, Nurjirana, Haris, et al. (2019b) reported the fish is composed of species in the Gobiidae family and Eleotridae family based on its morphological characters.

Sahami et al. (2019; 2019b), in her recent study reported that the composers of Nike fish cluster in Gorontalo Bay consist of four species (i.e. *S. pugnans* Ogilvie-Grant 1884, *S. cynocephalus Valenciennes* 1837, *Bunaka gyrinoides* Bleeker 1853, and *Belobranchus segura* Keith, Hadiaty and Lord 2012). These studies show that Nike is amphidromous Gobi assemblages with a high diversity of species and it is possible that there are species that are not yet identified and reported to date.

The high diversity of Nike fish is also supported by the high diversity of similar fish assemblages in other aquatic areas as reported by Nurjirana, Burhanuddin, et al. (2019a) in a research related to *Penja* fish in West Sulawesi consisting of six genera and nine species (i.e. *Sicyopterus lagocephalus* Pallas 1770, *Sicyopterus longifilis*, *Stiphodon semoni* Weber 1895, *Stiphodon atropurpureus* Herre 1927, *Sicyopus zosterophorum* Bleeker 1856, *Smilosicyopus leprurus* Sakai and Nakamura 1979, *Schismatogobius* sp., *Eleotris fusca* Forster 1801, and *Eleotris* sp.). Furthermore, Thomas et al. (2013) reported *Dulong* fish in Verde Island, Philippines, consisting of several species included in three families; Clupeidae, Gobiidae, and Scombridae (i.e. *Herklotsichthys quadrimaculatus* Rüppel 1837, *Sardinella gibbosa* Bleeker 1849, *Sardinella lemuru* Bleeker 1853, *Spratelloides delicatulus* Bennett 1832, *Sicyopterus pugnans*, *Sicyopterus lagocerastes* *lagocephalus*, and *Sicyopterus lagocer brachyosoma* *Rastrelliger brachyosoma* Bleeker 1851).

The popularity of Nike fish, which is much favored by the community and its high economic value, has a significant impact on the high level of fishing. It is feared that rapid environmental changes and uncontrolled capture will reduce diversity if no rapid and appropriate management is carried out.

The management can only be performed if this is supported by the availability of accurate and current scientific information. Therefore, it is necessary to explore the diversity of Nike fish composers which can be a reference information for main exploration and their distribution in nature. Accordingly, the mapping of distribution areas, as well as appropriate conservation actions and sustainable management can be carried out. The purpose of this study is to identify the species composers of Nike fish assemblages in Gorontalo Bay comprehensively based on morphometric and molecular characters and to find out their molecular phylogenetics.

MATERIALS AND METHOD

Sampling

The samples were obtained from the catches of fishermen's catches during the three occurrence periods (i.e. January–March 2019) in Gorontalo Bay to the estuary of Bone Bolango River (Figure 1). The sampling was carried out from the first day until the last day in each period of the appearance. The sampled fishes were temporarily preserved in an icebox (4 °C) and was transported to the laboratory for further analysis. The sample grouping referred to the initial method used by Sahami et al. (2019; 2019b) based on the differences in melanophoric pattern in the body. 20 groups of sample were found in this study, in which 15 groups were new melanophore patterns and coded with N6–N20, while five groups were the melanophore patterns that had been reported Sahami et al.

Formatted: Font: Not Italic

Formatted: Font: Not Italic

(2019a, 2019b). The measurement of morphometric characters was carried out on 20 groups of melanophore patterns, whereas the samples for molecular analysis were only obtained from 15 samples of newly discovered melanophore patterns. Immediately after the measurement of morphometric characters, Regarding the molecular analysis, five individuals were taken from each group and each of them was then filled-placed in a sample bottle and added with 95% ethanol solution for molecular analysis.

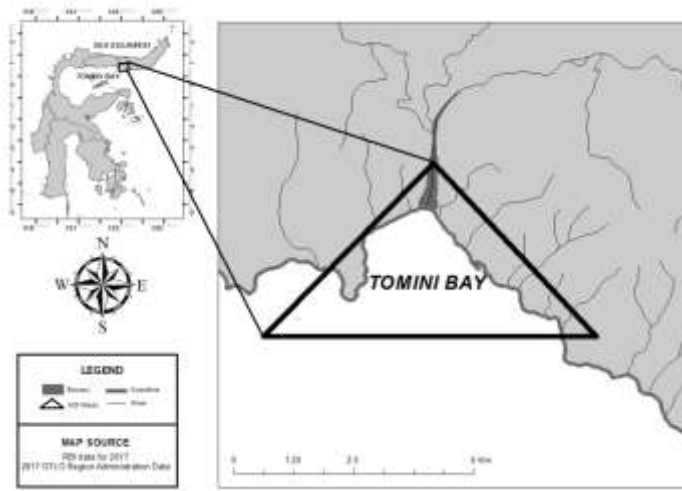

Figure 1. Map of the research location

Morphometric Characters

The morphometric characters of Nike fish consist of 10 characters modified from Benbow et al. (2004) (Figure 2 and Table 1). The measurement was performed using Image-J application.

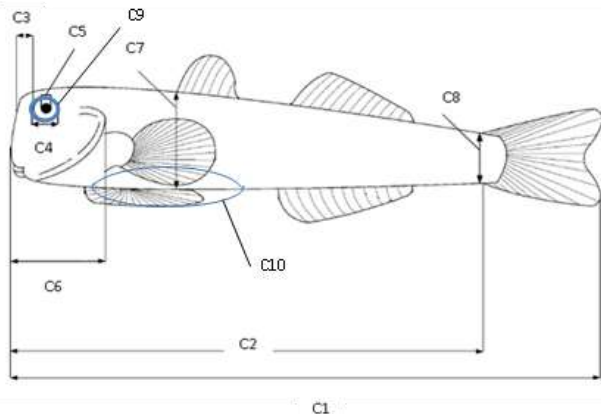

Figure 2. Morphometric Characters of Nike Fish (modified from Benbow et al., 2004)

Table 1. Morphometric Characters of Nike Fish (modified from Benbow et al., 2004)

No	Morphometric Characters	No	Morphometric Characters
C1	Total Length (TL)	C6	Head Length (HL)

Formatted Table

C2	Standard Length (SL)	C7	Body Depth (BD)
C3	Preorbital Length (PL)	C8	Peduncle Depth (PD)
C4	Eye Diameter (ED)	C9	Eye Area (EA)
C5	Eye Lens Pupil Diameter Diameter (EP)	C10	Yolk Sac area (YS)

Each measured morphometric character data was then standardized by following the allometric formula according to Elliott et al. (1995) as follows:

$$M_{adj} = M (L_s/L_0)^b$$

M_{adj} is the standardized morphometric data, M is the measured morphometric data, L_0 is the total length of fish, L_s is the average total length, and parameter b is the slope of log linear curve M to log L_0 of all data.

DNA Extraction, PCR Amplification, and Sequencing

Molecular analysis was carried out through several stages including collection of fish tissue, Deoxyribonucleic acid (DNA) **isolation/extraction**, Polymerase Chain Reaction (PCR) DNA, electrophoresis, and DNA sequencing. **The DNA was extracted** **isolation of the DNA sample was performed** using Genomic DNA Mini Kit Tissue by following the protocol of the kit. **Approximately ±30 mg samples of fish muscle tissue were taken and put into a 1.5 ml microcentrifuge tube, subsequently 200 ml GT Buffer was added and homogenized by grinding. Furthermore, 20 ml of Proteinase K was added and incubated at 60 °C for 30 minutes, with inverting the tube every 5 minutes during incubation. 200 ml GBT Buffer was added and vortexed for five seconds. The mixture was incubated at 60 °C for 20 minutes, with inverting the tube every 5 minutes. Also, 200 ml absolute ethanol was added and vortexed for 10 seconds, and then the sample was placed to the GS column in a 2 ml collection tube and centrifuged at 14,000-16,000 g for two minutes. The collection tube was discarded and transferred the GS column to a new collection tube. 400 ml W1 Buffer was added to the GS column and centrifuged at 14,000-16,000 g for thirty seconds. The supernatant was removed, and the 600 ml Wash Buffer was added to the GS column and centrifuged at 14,000-16,000 g for thirty seconds. After that, the supernatant was discharged, and the GS column was placed back in the collection tube and centrifuged at 14,000-16,000 g for three minutes. In the final step, the dried GS column was placed to a clean microcentrifuge tube, and the pre-heated Elution Buffer was added and centrifuged at 14,000-16,000 g for thirty seconds.**

The mitochondrial Cytochrome Oxidase subunit I (COI) gene was chosen because the resolution of the COI gene at the intraspecific level is better than other core genes, so it was appropriate to be used to identify the species up to the intraspecific level (Strüder-Kypke and Lynn, 2010). The mitochondrial DNA COI gene was further amplified using a forward primer pair FF2d 5'-TTC TCC ACC AAC CAC AAR GAY ATY GG-3' and reverse primer FR1d 5'-CAC CTC AGG GTG TCC GAA RAA YCA RAA-3' (Ivanova et al. 2007). One sample, i.e. N16, was amplified using the LCOI490 forward primer pair (5'-GGT CAA CAA ATA ATA AAG ATA TTG G-3') and reverse primer HC02198 5'-TAA ACT TCA GGG TGA CCA AAA AAT CA-3' (Folmer et al. 1994) because it was unsuccessfully amplified using FF2d and FR1d primers. The PCR profiles were pre-denaturation at 94 °C for five minutes, denaturation at 94 °C for 30 seconds, primary attachment at 50 °C for 30 seconds, elongation at 72 °C for 45 seconds, and final elongation at 72 °C for seven minutes. The PCR process lasted for 40 cycles and the DNA samples that had been amplified and electrophoresed were then sequenced. The sequencing process was performed at Malaysia's 1st Base Laboratory through PT Genetika Science Indonesia by sending samples consisting of PCR Product of 30 µl DNA samples, 10 µl forward primers, and 10 µl reverse primers.

Data Analysis

Morphometric characters were analyzed using Discriminant Function Analysis (DFA) (Landau and Everit, 2004) using IBM SPSS Statistics 20. The molecular data sequencing process was carried out

using Dideoxy Sanger Termination Method through PT Genetika Science Indonesia. Nucleotide sequences from DNA sequencing that had been processed and carried out by CONTIG were then matched with data available on the GenBank database National Center for Biotechnology Information (NCBI) databases (www.ncbi.nlm.nih.gov) through the BLAST (Basic Local Alignment Search Tool). Phylogenetic trees are arranged by aligning the DNA sequences of the identified samples with some gobi DNA samples available in the GenBank database. The phylogenetic tree was created using Maximum Likelihood 1000 bootstrap method in MEGA 6.0 software.

RESULTS AND DISCUSSION

Species Identification

Nike is a group of small fish at the post-larval and juvenile stages which generally have a transparent body at the beginning until they turn blackish at the end of the appearance period when the fish have entered the river estuary. Based on a cursory observation, Nike fish is a composition of small fish grouped with the same morphological appearance. However, if this is observed in detail, the fish show a variety of melanophore patterns on their bodies. From a total of 2,523 Nike fish samples caught during the study period, 1,856 fish samples were found with different melanophore patterns than previously reported by Sahami et al. (2019a, 2019b). This study found 15 new melanophore patterns (sample code N6-N20) presented in Figure 3.

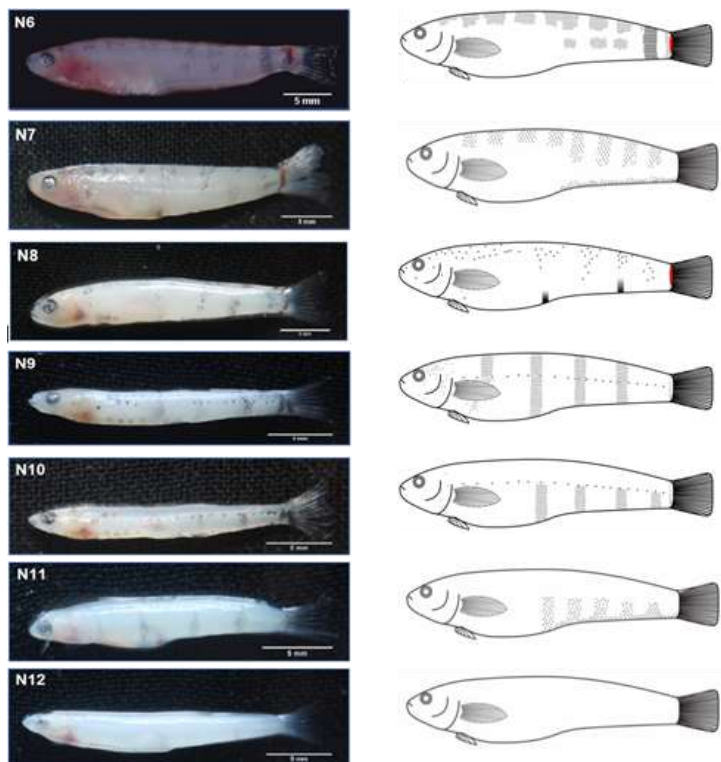

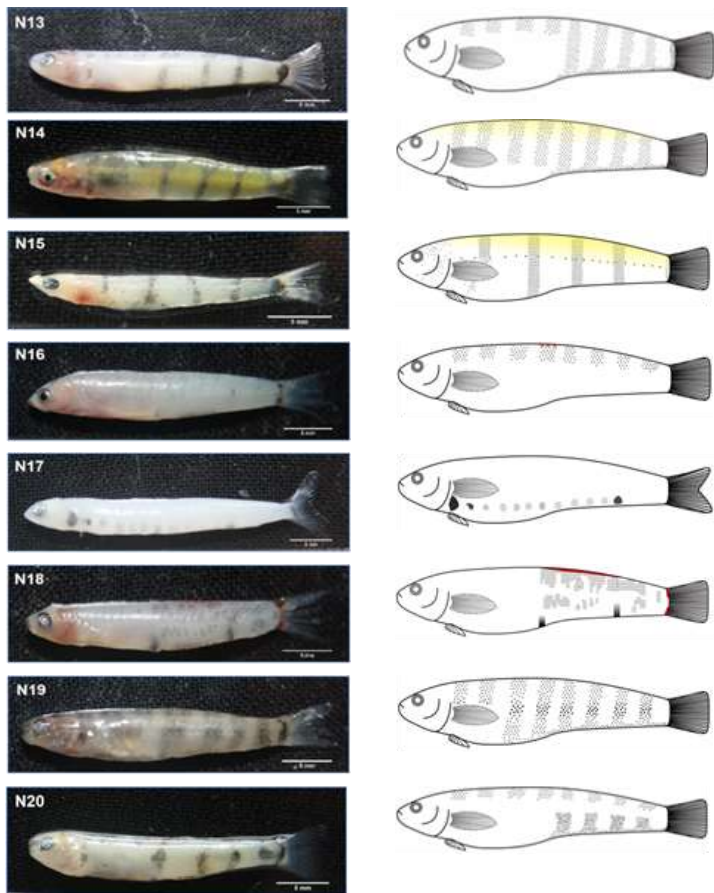

Figure 3. A New Record on the Diversity of Species Composers of Nike Fish in Gorontalo Bay Waters (notes: sketch of melanophore pattern does not use actual fish size)

The caught Nike fish have a total length of 16.22–37.69 mm in general, do not have scales, the fins are not perfect, and the caudal fins tend to form truncates. One sample, i.e. N17, is the only sample whose caudal fins form a clear fork. Each group of melanophore pattern was caught in a range of different sizes as presented in Table 2.

Table 2. Range of Catch Size of Each Species Composer of Nike Fish Assemblages in Gorontalo Bay

Sample Code	Mean of Total Length (cm)	Range of Total Length (cm)	Number of Samples
N1	2.765	1.964–3.547	508
N2	2.764	2.383–3.326	81
N3	2.153	1.917–2.372	54
N4	2.089	2.089	1
N5	2.063	1.892–1.943	23
N6	3.043	2.345–3.658	190
N7	2.777	2.415–3.748	399
N8	2.796	2.379–3.333	277
N9	2.204	1.897–2.362	27
N10	2.314	2.283–2.344	2

Formatted Table



N11	1.931	1.622–2.103	140
N12	2.019	1.694–2.369	191
N13	2.767	2.480–3.347	240
N14	2.642	2.386–2.863	50
N15	2.181	2.002–2.357	42
N16	3.042	2.579–3.769	129
N17	3.768	3.768	1
N18	2.952	2.840–3.118	4
N19	3.208	2.900–3.507	31
N20	2.774	2.452–3.628	133
Total Sample			2,523

Table 2 shows that the Nike fish assemblages do not only consist of fish with different melanophoric patterns, but also different sizes. In a single Nike catch, the size of each group of melanophore patterns is very diverse and shows a certain tendency to group. The highest caught samples in the observation period were 501 N1, while the lowest caught samples were N4 and N17 (i.e. one sample for each).

Morphometric Data Analysis

Morphometric characters can be used in taxonomies as initial identification in fisheries (Sara et al., 2016). A summary of the results of morphometric characters data measurements that have been standardized follows the allometric formula Elliott et al. (1995) as presented in Table 3.

Table 3. Morphometric Characters Data of Each Species Composer of Nike Fish Assemblages in Gorontalo Bay

Sample Code	Unit of Character (cm)								
	SL	PL	ED	EP	HL	BD	PD	EA	YS
N1	2.237 ± 0.10	0.112 ± 0.02	0.131 ± 0.01	0.116 ± 0.13	0.447 ± 0.04	0.403 ± 0.09	0.188 ± 0.08	0.018 ± 0.01	0.063 ± 0.02
N2	2.214 ± 0.05	0.117 ± 0.02	0.132 ± 0.02	0.057 ± 0.02	0.442 ± 0.05	0.405 ± 0.04	0.228 ± 0.03	0.014 ± 0.00	0.060 ± 0.03
N3	2.257 ± 0.07	0.137 ± 0.01	0.136 ± 0.01	0.073 ± 0.02	0.525 ± 0.03	0.383 ± 0.02	0.155 ± 0.01	0.018 ± 0.00	0.038 ± 0.02
N4	2.333 ± a	0.118 ± a	0.166 ± a	0.086 ± a	0.841 ± a	0.502 ± a	0.183 ± a	0.023 ± a	0.201 ± a
N5	2.258 ± 0.08	0.158 ± 0.02	0.150 ± 0.01	0.095 ± 0.02	0.557 ± 0.04	0.379 ± 0.02	0.156 ± 0.02	0.022 ± 0.00	0.065 ± 0.03
N6	2.246 ± 0.04	0.118 ± 0.02	0.130 ± 0.01	0.141 ± 0.17	0.476 ± 0.04	0.406 ± 0.10	0.197 ± 0.11	0.030 ± 0.04	0.071 ± 0.04
N7	2.243 ± 0.04	0.114 ± 0.02	0.133 ± 0.01	0.144 ± 0.02	0.438 ± 0.03	0.390 ± 0.10	0.179 ± 0.09	0.018 ± 0.01	0.062 ± 0.02
N8	2.238 ± 0.01	0.116 ± 0.02	0.133 ± 0.01	0.168 ± 0.18	0.456 ± 0.05	0.381 ± 0.11	0.168 ± 0.11	0.023 ± 0.02	0.072 ± 0.03
N9	2.211 ± 0.04	0.146 ± 0.02	0.128 ± 0.02	0.062 ± 0.02	0.525 ± 0.03	0.365 ± 0.02	0.161 ± 0.02	0.016 ± 0.00	0.046 ± 0.02
N10	2.205 ± 0.04	0.120 ± 0.00	0.138 ± 0.00	0.039 ± 0.01	0.502 ± 0.01	0.344 ± 0.01	0.169 ± 0.00	0.017 ± 0.00	0.045 ± 0.01
N11	2.222 ± 0.04	0.095 ± 0.02	0.131 ± 0.01	0.083 ± 0.02	0.411 ± 0.04	0.376 ± 0.03	0.122 ± 0.02	0.018 ± 0.00	0.080 ± 0.03
N12	2.256 ± 0.04	0.108 ± 0.02	0.123 ± 0.01	0.074 ± 0.02	0.434 ± 0.03	0.349 ± 0.04	0.116 ± 0.02	0.015 ± 0.00	0.061 ± 0.04
N13	2.245 ± 0.04	0.112 ± 0.02	0.132 ± 0.01	0.154 ± 0.16	0.456 ± 0.04	0.389 ± 0.11	0.172 ± 0.20	0.022 ± 0.02	0.059 ± 0.02
N14	2.240 ± 0.03	0.111 ± 0.01	0.139 ± 0.01	0.061 ± 0.01	0.445 ± 0.03	0.381 ± 0.03	0.210 ± 0.02	0.015 ± 0.00	0.047 ± 0.01
N15	2.189 ± 0.04	0.154 ± 0.02	0.140 ± 0.01	0.079 ± 0.02	0.543 ± 0.04	0.356 ± 0.02	0.177 ± 0.01	0.018 ± 0.01	0.056 ± 0.02
N16	2.216 ± 0.04	0.111 ± 0.02	0.133 ± 0.01	0.045 ± 0.001	0.438 ± 0.05	0.394 ± 0.03	0.258 ± 0.03	0.012 ± 0.00	0.051 ± 0.01
N17	2.352 ± a	0.069 ± a	0.122 ± a	0.039 ± a	0.387 ± a	0.272 ± a	0.187 ± a	0.010 ± a	0.047 ± a
N18	2.229 ± 0.02	0.110 ± 0.02	0.133 ± 0.00	0.049 ± 0.00	0.409 ± 0.01	0.369 ± 0.02	0.252 ± 0.02	0.010 ± 0.00	0.037 ± 0.01
N19	2.225 ± 0.03	0.113 ± 0.01	0.124 ± 0.00	0.038 ± 0.00	0.440 ± 0.02	0.460 ± 0.03	0.279 ± 0.02	0.009 ± 0.00	0.057 ± 0.02
N20	2.243 ± 0.05	0.109 ± 0.01	0.131 ± 0.01	0.172 ± 0.17	0.462 ± 0.05	0.369 ± 0.10	0.152 ± 0.10	0.029 ± 0.03	0.065 ± 0.02

Discriminant analysis is an analysis used to define morphometric characters distinguishing among populations (Landau and Everit, 2004). The distribution of the discriminant coefficient values presented in the form of canonical discriminant function diagrams shows the 20 types of species that compose the Nike fish assemblages with different melanophore patterns in Gorontalo Bay forming three clusters as presented in Figure 4.

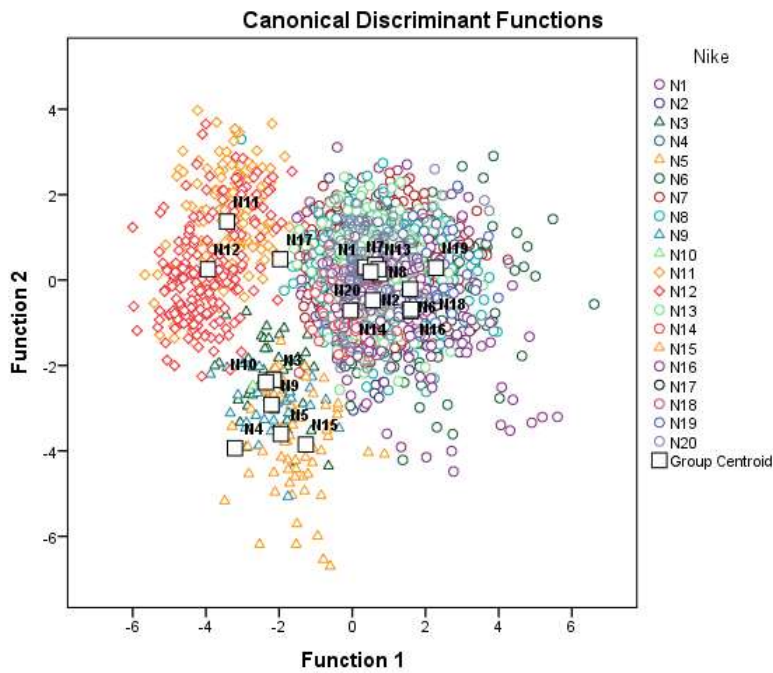

Figure 4. Diagram of the canonical discriminant function of Nike fish in Gorontalo Bay Waters. Each of the two discriminant functions can describe 63.9% and 19% of the total morphometric variant characters. Based on the analysis of discriminant functions, the C6 (head length) character was the highest character, which suggested that the main distinguishing character among Nike populations in the Gorontalo Bay waters could be determined from the head length character. Figure 4 obviously shows that Nike fish samples in the Gorontalo Bay waters formed ~~three~~ four clusters, N1, N2, N4, N6, N7, N8, N13, N14, N16, N18, N19 and N20) in the first cluster; N3, N4, N5, N9, N10, and N15 in the second cluster; ~~and~~ N11 and N12 in the third cluster; ~~and~~ ~~One~~ ~~one~~ sample, i.e. N17 in the fourth cluster. ~~does not show a tendency to be included in certain cluster since the number of samples was only one during the observation period.~~ Sahami et al. (2019a, 2019b) reported species N1 as *S. pugnans*; N2 as *S. cynocephalus*; N3 and N5 as *B. segura*; and N4 as *B. gyrinoides*. The diagram of canonical discriminant function classifies N1 and N2 in the first cluster, so it is strongly alleged that other species in the first cluster (N4, N6, N7, N8, N13, N14, N16, N18, N19, and N20) are species in the *Sicyopterus* genus or at least is a species in the Gobiidae family. Also, N3, N4, and N5 as species in Eleotridae family are present in the second cluster, so it is also strongly alleged that other species in the second cluster (N9, N10, and N15) are the members of Eleotridae family. On the other hand, N11 and N12 as separate clusters have not yet ascertained for the tendency of their species identity. However, the morphological character with

the fused abdominal-pelvic fins implies that both species are the members of Gobiidae family and not generated from the *Sicyopterus* genus. Nurjirana, Harris et al. (2019b) stated that the fundamental difference from the morphology of Gobiidae and Eleotridae fish lies in the shape of the abdominal-pelvic fins, where the Gobiidae fish has a fused abdominal-pelvic fins, forming a ventral disc and Eleotridae has a separated pelvic fins.

Molecular Analysis

The molecular analysis succeeded in identifying 14 of the 15 new melanophore pattern samples, while one sample, N17, was not identified since the sample was damaged and there were no more sample reserves. The results of mitochondrial COI gene sequencing indicate that the Nike fish assemblages in Gorontalo Bay had a high level of diversity with the discovery of six different species as their composers. The results of BLAST of DNA mitochondrial COI gene sequence data on www.blast.ncbi.nlm.nih.gov are presented in Table 4.

Table 4. The Results of Nike Fish BLAST in Gorontalo Bay on NCBI Website

Sample Code	Species	Sample Code	Species
N6	<i>Sicyopterus parvei</i>	N13	<i>Sicyopterus longifilis</i>
N7	<i>Sicyopterus longifilis</i>	N14	<i>Sicyopterus longifilis</i>
N8	<i>Sicyopterus cynocephalus</i>	N15	<i>Belobranchus belobranchus</i>
N9	<i>Belobranchus belobranchus</i>	N16	<i>Sicyopterus cynocephalus</i>
N10	<i>Belobranchus belobranchus</i>	N18	<i>Sicyopterus lagocephalus</i>
N11	<i>Stiphodon semoni</i>	N19	<i>Sicyopterus parvei</i>
N12	<i>Stiphodon semoni</i>	N20	<i>Sicyopterus longifilis</i>

Some samples with different melanophores had the same genetic profile so that they were identified as the same species. Table 3 shows that the Nike fish assemblages in Gorontalo Bay is composed of six species from two different families (i.e. *S. parvei* Bleeker 1853, *S. cynocephalus*, *S. longifilis*, *S. lagocephalus*, and *Stiphodon semoni*) from the Gobiidae family; and *Belobranchus belobranchus* Valenciennes 1837 from the Eleotridae family. One species, *S. longifilis*, is the same species as reported by Ollii et al. (2019) without a description of specific melanophore patterns and one species, *S. cynocephalus*, is also the same species with a different melanophore pattern as reported by Sahami et al. (2019, 2019b).

The results of molecular analysis were able to identify the samples up to the species level and further clarify the results of morphometric analysis. The first cluster was a species school in the genus *Sicyopterus*; the second cluster is a species school in the Eleotridae family; and the third cluster is a species school in the genus *Stiphodon*. Alleged N11 and N12 samples as the members of species in the Gobiidae family and not the members of species in the genus *Sicyopterus* were also confirmed through molecular analysis that succeeded in identifying the two species as *Stiphodon semoni* species. Overall, it can be emphasized that Nike fish has a fairly high level of diversity, both in terms of its constituent species and melanophore patterns at the species level. The overall kinship relationships of the species of Nike fish assemblages in the Gorontalo Bay waters based on the nucleotide sequence of the mitochondrial DNA COI gene are presented in Figure 5.

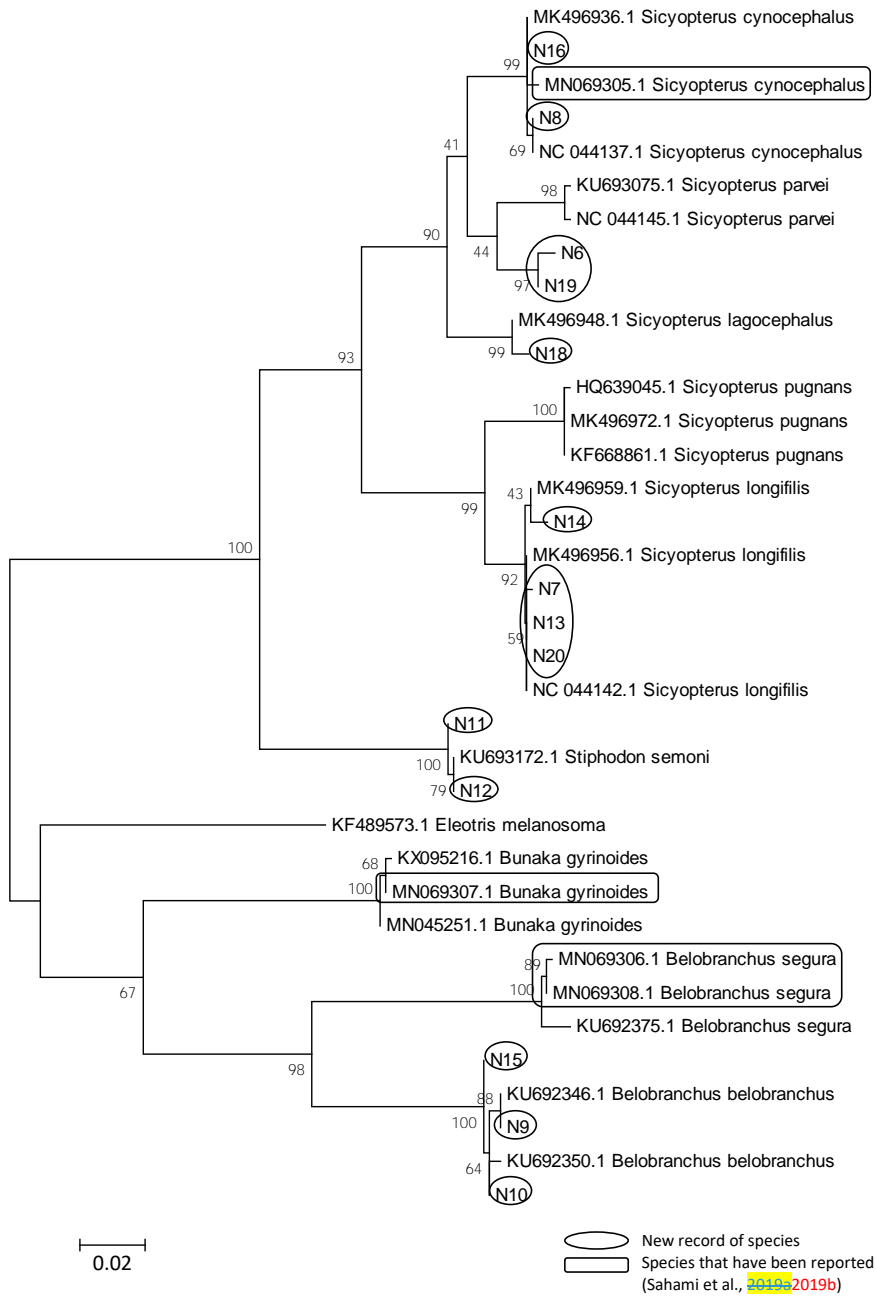

Figure 5. Phylogenetic Tree of Nike fish School Composers in the Gorontalo Bay Waters

The phylogenetic tree (Figure 5) shows that the species composing the Nike fish in the Gorontalo Bay waters form two monophyletic clades as family clades. The first monophyletic clade is the Gobiidae family clade which includes two genera and six species. The first genus is *Sicyopterus* which includes five species (i.e. *S. cynocephalus*, *S. parvei*, *S. lagocephalus*, *S. longifilis*, and *S. Pugnans*). The second genus is *Stiphodon* which consists of only one species (i.e. *Stiphodon semoni*). The second monophyletic clade is the Eleotridae family which includes two genera and three species (i.e. *Bunaka gyrinoides*, *Belobranchus segura*, and *B. Belobranchus*).

Discussion

This fish school migration strategy is a consequence of the amphidromus species in avoiding predators and foraging food when migrating from marine waters at the post-larval stage to the river (Keith, 2003). According to Thacker and Roje (2011), the diversity of Gobies at the post-larval and juvenile stages is often unnoticed because of their small size and unclear ecology. The use of melanophore pattern in morphological grouping is inspired by the research conducted by Yamasaki et al. (2011) which stated that the larvae of newly hatched gobi can be distinguished based on their melanophore pattern.

This study found 15 new melanophoric patterns (Figure 3) that can distinguish and classify the fish composing Nike fish assemblages from one another. The combination of their morphological characters and diagram of canonical discriminant function (Figure 4) shows that morphometric characters can be used in determining samples up to family level, but it cannot identify the samples up to the genus or even species level. These results are in line with research conducted by Watanabe et al. (2011) which also had not been able to identify the *S. japonicus* post-larvae based on its morphological characters since the morphology is still very common as the morphological characters of other Gobioidae fish larvae. Thacker and Roje (2011) stated that Gobiidae fish have few morphological characters that can be used to group subgroups in the family even though the diversity of its species is quite high. Akihito et al. (2009); Roesma et al. (2020) said that Gobies develop various morphological specialties as an adaptation to their environment, making it difficult to estimate the evolutionary scenarios by using a morphological information only.

Subsequently, molecular identification was performed to confirm the identity of species that cannot be demonstrated either by the morphological features of the species or their morphometric characters. Mitochondrial DNA markers (mtDNA) had been widely used for most systematic molecular studies compared to nuclear DNA due to the large number of copies obtained from one cell, their small size, haploid in nature, and evolving faster (Teletchea, 2009). The COI gene is the fastest and most reliable gene used as a barcoding marker to identify species (Hubert et al., 2008; Bingpeng et al., 2018; Roesma et al., 2018; Roesma et al., 2019). Initially, the COI gene have also been widely used to identify the species in Gobioidae assemblages (Jeon et al., 2012; Thomas et al., 2013; Viswambharan et al., 2013; Jin et al., 2014; Taillebois et al., 2014; Lejeune et al., 2016; Wang et al., 2017; Linh et al., 2018; Ollii et al., 2019; Roesma et al., 2020). Therefore, this study also used the COI gene to identify species.

Several samples with different melanophore patterns were found having the same genetic identity. This was affected by some factors, such as environment, age, and nature of dichromatism that might appear when the adult stage. Ellien et al. (2014); Valade et al. (2009) explained that *S. lagocephalus* larvae changes in the appearance of chromatophores in its body that starts from the head area and spreads along the body as the larvae get older. The identical results were obtained by Sahami et al. (2019a), which found an increase in the number of melanophores in the body of the Nike *Belobranchus segura* fish when entering the estuary areas. Keith (2003) noted that freshwater Gobioidae fish are not hermaphrodite and do not sexually change or have alternative sexual

strategies, but usually occur in sexual dichromatism in adult stage, where males have a brighter color than females. Larmuseau et al. (2010), in his research, revealed that natural selection might also affect the genetic variation in cone opsins in species that could have an impact on the evolution of polymorphism.

The results of molecular identification indicate that the **new melanophore patterns of Nike fish** in Gorontalo Bay waters were composed of six species (i.e. *S. parvei*, *S. cynocephalus*, *S. longifilis*, *S. lagocephalus*, *B. Belobranthus*, and *Stiphodon semoni*). Nike fish was initially reported as a single species *A. Melanocephalus* by Usman (2016) and *Sicyopterus longifilis* by Ollie et al. (2019). Recently, Sahami et al. (2019, 2019b) found the diversity of the composers species of Nike fish in *S. pugnans*, *S. cynocephalus*, *Bunaka gyrinoides*, and *Belobranthus segura*. This study successfully found and identified four new composers species of Nike fish, such as *S. parvei* and *S. lagocephalus*, and *Stiphodon semoni* generated from the Gobiidae family, and *B. Belobranthus* generated from the Eleotridae family.

94.09% (2,374 samples) out of a total of 2,523 samples whose morphometric characters were observed are species in the Gobiidae family. In addition to the high quantity of the catches, the species in the Gobiidae family also show its highest diversity of melanophore and genetic patterns compared to the Eleotridae family. According to Thacker and Roje (2011), Gobiidae is one of the largest Acanthomorph fish assemblages consisting of $\pm 1,120$ species from 30 genera that have been described. Sicydiinae subfamily (Teleostei: Gobioidae) is the largest subfamily that contributes to the diversity of fish communities in tropical river waters with nine genera and more than 110 species that have been described. Nine genera of the Sicydiinae subfamily are *Sicydium* Valenciennes, 1837; *Sicyopterus* Gill, 1860; *Lentipes* Günther, 1861; *Sicyopus* Gill, 1863; *Cotylopus* Guichenot, 1864; *Stiphodon* Weber, 1895; *Parasicydium* Risch, 1980; *Smilosicyopus* Watson, 1999; and *Akihito* Watson, Keith and Marquet, 2007 (Keith et al. 2011; Taillebois et al. 2014). The genus *Sicyopterus* of the Sicydiinae subfamily is the genus with the highest diversity of species and is widely distributed to the Indo-Pacific tropical islands (Keith et al. 2005; Keith et al. 2015; Lord et al. 2019). It strengthens the results of this study which found *Sicyopterus* as the genus with the highest diversity of Gorontalo Bay waters.

The *S. parvei* species are known to be Indonesian local endemic (LE) (Lord et al. 2019). Its distribution in Indonesia was found in Manggarai, Flores (Tjakrawidjaja 2002); Sukamade river, East Java (Rukmana et al. 2014); and Java and Bali. Meanwhile, *S. lagocephalus* species is known as the species of genus *Sicyopterus* with the most extensive distribution in the Indo-Pacific region (Keith et al. 2005; Lord et al. 2019). This species was also found in La Réunion island (Keith et al., 2008); Vanuatu, Futuna and Okinawa (Keith et al. 2011); Buleleng, Bali (Dahrudin et al. 2016); Leppangan river, East Sulawesi (Nurjirana, Burhanuddin, et al. 2019a); and Luwuk Banggai, Central Sulawesi (Gani et al. 2019).

The adult species of *B. belobranthus* was found in Bone river, Gorontalo (Pasingi et al. 2020) and further strengthen the discovery at the post-larval and juvenile stages in this study. Besides, the distribution of this species in Indonesia had been reported in Manggarai, Flores (Tjakrawidjaja 2002); Sukamade, East Java (Rukmana et al. 2014); and Luwuk Banggai, Central Sulawesi (Gani et al. 2019). The discovery of *B. belobranthus* species in the Gorontalo Bay waters contributes to the diversity of species in the genus *Belobranthus* which was previously only found for one species, i.e. *B. segura*.

The *Stiphodon semoni* species, the Opal cling goby, is one of the economically important species in the world of ornamental fish trade (Maeda and Tan, 2013; Hubert et al. 2015). The distribution of this species in Indonesia was found in Lampung (Watson, 2008), Bengkulu (Maeda & Tan, 2013),

Sukabumi, West Java (Dahrudin *et al.*, 2016); Leppangan River, West Sulawesi (Nurjirana, Burhanuddin, *et al.*, 2019a); and Luwuk Banggai, Central Sulawesi (Gani *et al.*, 2019).

The *A. melanocephalus* species, that was initially reported by Usman (2016) as a Nike species in Gorontalo Bay, was not found in this study because the sampling time did not coincide with the spawning time of the species. As explained in Yamasaki *et al.* (2011), it showed that the spawning season for *A. melanocephalus* was June to November, while the sampling was done in January–March. Besides, species extinction might occur due to overfishing and habitat change. However, in-depth research needs to be conducted to fulfill a scientific information on Gorontalo aquatic biodiversity.

Having described above, it has been genetically confirmed for 10 species of Gobies as a constituent of the Nike fish **cluster-assemblages** in the Gorontalo Bay waters to date and it is possible to find more other species in line with further advance in science and research. This study has been successfully grouping and identifying the species based on their morphometric and molecular characters, as well as being the initial identity of the melanophore pattern characters of each Nike fish compiler. These data are also very worthwhile as the reference for the inventory of Nike fish species in other places on the coast of Tomini Bay and other areas. Salam *et al.* (2016) stated that Nike fish assemblages in Gorontalo could be found in several *milango* (estuary areas). Besides being found in the estuary of the Bone Bolango River in Gorontalo, which is the location of this study, Nike fish assemblages also often appear in several estuary areas (i.e. Taludaa, Paguyaman, and Marisa). Nike fish caught at these locations are also consumed by the local community or sold in urban areas, making it one of the important fisheries commodities in Gorontalo. However, scientific information concerning Nike fish in these locations does not yet exist and should be sought as soon as possible. The results of this study can also be an information for exploring adult gobies in the river and finding out their distribution in nature.

ACKNOWLEDGEMENTS

The authors would like to express their gratitude to the Rector of Gorontalo State University for granting permission and supporting the accomplishment of this study. Also, the greatest gratitude goes to Mohamad Rusdiyanto Pulu Hulawa for the research fund. The authors also thank Thomas Tammu and Zulkifli Karim for their technical assistance and all those who have contributed to this study. Finally, the authors thank the anonymous reviewers for their constructive input and contribution in improving the quality of this manuscript.

REFERENCES

- Benbow ME, Burky AJ, Way CM. 2004. Morphological characteristics and species separation of Hawaiian postlarval amphidromous fishes. *Micronesica* 37 (1): 129–144.
- Bingpeng X, Heshan L, Zhilan Z, Chunguang W, Yanguo W, Jianjun W. 2018. DNA barcoding for identification of fish species in the Taiwan Strait. *PLoS One* 13 (6): e0198109.
- Dahrudin H, Hutama A, Busson F, Sauri S, Hanner R, Keith P, Hadiaty R, Hubert N. 2016. Revisiting the ichthyodiversity of Java and Bali through DNA barcodes: taxonomic coverage, identification accuracy, cryptic diversity and identification of exotic species. *Mol Ecol Resour* 17 (2): 1–12.
- Ellien C, Werner U, Keith P. 2014. Morphological changes during the transition from freshwater to sea water in an amphidromous goby, *Sicyopterus lagocephalus* (Pallas 1770) (Teleostei). *Ecol Freshw Fish* 25 (1): 1–12.
- Elliott NG, Haskard K, Koslow JA. 1995. Morphometric analysis of orange roughy (*Hoplostethus atalanticus*) off the continental slope of southern Australia. *J Fish Biol* 46 (2): 202–220.
- Ellien C, Werner U, Keith P. 2014. Morphological changes during the transition from freshwater to sea water in an amphidromous goby, *Sicyopterus lagocephalus* (Pallas 1770) (Teleostei). *Ecol Freshw Fish* 25 (1): 1–12.
- Folmer O, Black M, Hoeh W, Lutz R, Vrijenhoek R. 1994. DNA primers for amplification of mitochondrial Cytochrome C Oxidase subunit I from diverse metazoan invertebrates. *Mol Mar Biol and Biotechnol* 3 (5): 294–299.
- Gani A, Bakri AA, Adriany DT, Nurjirana N, Herjayanto M, Bungalim MI, Ndobe S, Burhanuddin AI. 2019. Identification of freshwater goby species from The Biak and Koyoan Rivers, Luwuk Banggai, Central Sulawesi. *J Ilmu Kel Spermonde* 5 (2): 57–60.
- Hubert N, Hanner R, Holm E, Mandrak NE, Taylor E, Burrige M, Watkinson D, Dumont P, Curry A, Bentzen P, Zhang J, April J, Bernatchez L. 2008. Identifying Canadian freshwater fishes through DNA barcodes. *PLoS One* 3(6): e2490.

- Hubert N, Kadarusman, Wibowo A, Busson F, Caruso D, Sulandari S, Nafiqoh N, Poiyaud L, Ruber L, Avarre JC, Herder F, Hanner R, Keith P, Hadiaty RK. 2015. DNA Barcoding Indonesian freshwater fishes: challenges and prospects. *DNA Barcodes* 3: 144–169.
- Ivanova NV, Zemlak TS, Hanner RH, Hebert PDN. 2007. Universal primer cocktails for fish DNA barcoding. *Mol Ecol Notes* 7(4): 544–548.
- Jeon HB, Choi SH, Suk HY. 2012. Exploring the utility of partial cytochrome c oxidase subunit I for DNA barcoding of gobies. *Anim Syst Evol Divers* 28 (4): 269–278.
- Jin X, Wang R, Wei T, Tang D, Xu T, [2014](#). Complete mitochondrial genome sequence of *Tridentiger bifasciatus* and *Tridentiger barbatus* (Perciformes, Gobiidae): a mitogenomic perspective on the phylogenetic relationships of Gobiidae. *Mol Biol Rep* 42: 253–265.
- Keith P. 2003. Biology and ecology of amphidromous Gobiidae of the Indo-Pacific and the Caribbean regions. *J Fish Biol* 63: 831–847.
- Keith P, Galewski T, Cattaneo-Berrebi G, Hoareau T, Berrebi P. 2005. Ubiquity of *Sicyopterus lagocephalus* (Teleostei: Gobiidae) and phylogeography of the genus *Sicyopterus* in the Indo-Pacific area inferred from mitochondrial cytochrome b gene. *Mol Phylogenet Evol* 37: 721–732.
- Keith P, Hoareau TB, Lord C, Ah-Yane O, Gimonneau G, Robinet T, Valade P. 2008. Characterisation of post-larval to juvenile stages, metamorphosis and recruitment of an amphidromous goby, *Sicyopterus lagocephalus* (Pallas) (Teleostei : Gobiidae : Sicydiinae). *Mar Freshwater Res* 59: 876–889.
- Keith P, Lord C, Lorion J, Watanabe S, Tsukamoto K, Couloux A, Dettai A. 2011. Phylogeny and biogeography of Sicydiinae (Teleostei: Gobiidae) inferred from mitochondrial and nuclear genes. *Mar Biol* 158: 311–326.
- Keith P, Lord C, Busson F, Sauri S, Hubert N, Hadiaty RK. 2015. A new species of *Sicyopterus* (Gobiidae) from Indonesia. *Cybius* 39 (4): 243–248.
- Landau S, Everit BS. 2004. *A Handbook of Statistical Analyses using SPSS*. Chapman & Hall/CRC, Washington DC.
- Larmuseau MHD, Vancampenhout K, Raeymaekers JAM, Houdt KJ, Volckaert FAM. 2010. Differential modes of selection on the rhodopsin gene in coastal Baltic and North Sea populations of the sand goby, *Pomatoschistus minutus*. *Mol Ecol* 19 (11): 2256–2268.
- Lejeune L, Tabouret H, Taillebois L, Monti D, Keith P. 2016. Larval traits of the Caribbean amphidromous goby *Sicydium punctatum* (Gobiidae: Sicydiinae) in Guadeloupe. *Ecol Freshw Fish* 25 (2): 272–280.
- Linh NM, Thu PT, Quan NV, Chien PV, Ly DH, Nhan DV, Len DT. 2018. DNA barcoding application of mitochondrial COI gene to identify some fish species of family Gobiidae in Vietnam. *J Mar Sci Tech-Japan* 18 (4): 433–451.
- Lord C, Bellec L, Dettai A, Bonillo C, Keith P. 2019. Does your lip stick? Evolutionary aspects of the mouth morphology of the Indo-Pacific clinging goby of the *Sicyopterus* genus (Teleostei: Gobiidae: Sicydiinae) based on mitogenome phylogeny. *J Zool Syst Evol Res* 2019:00: 1–16.
- Maeda K, Tan HH. 2013. Review of *Stiphodon* (Gobiidae: Sicydiinae) from Western Sumatra, with Description of a New Species. *Raffles B Zool* 61 (2): 749–761.
- Mennesson MI, Maeda K, Keith P. 2019. Evolutionary aspects of cephalic sensory papillae of the Indo-Pacific species of Eleotris (Teleostei: Eleotridae). *Zool Scr* 48 (5): 627–639.
- Nurjirana, Burhanuddin AI, Haris A. 2019a. Diversity of penja fish (amphidromous goby) in Leppangan River, West Sulawesi, Indonesia. *AAAL Bioflux* 12 (1): 246–249.
- Nurjirana, Haris A, Sahami FM, Keith P, Burhanuddin AI. 2019b. Preliminary note on the morphological characters of penja (amphidromous goby post larvae) in West Sulawesi and Gorontalo Bay. *IOP Conference Series: Earth and Environ Sci* 370 (1): 1–7.
- Olii AH, Sahami FM, Hamzah SN, Pasingi N. 2017. Preliminary findings on distribution pattern of larvae of nike fish (*Awaous* sp.) in the estuary of Bone River, Gorontalo Province, Indonesia. *AAAL Bioflux* 10: 1110–1118.
- Olii AH, Sahami FM, Hamzah SN, Pasingi N. 2019. Molecular approach to identify gobioid fishes, "Nike" and "Hundala" (local name), from Gorontalo Waters, Indonesia. *Online J Biol Sci* 19 (1): 51–56.
- Pasingi N, Abdullah S. 2018. Pola kemunculan ikan nike (Gobiidae) di Perairan Teluk Gorontalo, Indonesia. *Depik* 7 (2): 111–118. [Indonesian]
- Pasingi N, Habbib SA, Olii AH. 2020. Are *Awaous ocellaris* and *Belobranchius belobranchius* the two species of Nike fish schools?. *Aceh J Anim Sci* 5 (2): 87–91.
- Roesma DI, Tjong DH, Munir W, Aidil DR. 2018. New record species of *Puntius* (Pisces: Cyprinidae) from West Sumatra based on cytochrome oxidase I gene. *Int J Adv Sci Eng Inf Techno* 8: 250–256.
- Roesma DI, Tjong DH, Karlina W, Aidil DR. 2019. Taxonomy confirmation of *Puntius* cf. *binotatus* from Gunung Tujuh Lake, Jambi, Indonesia based on cytochrome oxidase-I (COI) gene. *Biodiversitas* 20 (1): 54–60.
- Roesma DI, Tjong DH, Aidil DR. 2020. Phylogenetic analysis of transparent gobies in three Sumatran lakes, inferred from mitochondrial cytochrome oxidase I (COI) gene. *Biodiversitas* 21 (1): 43–48.
- Rukmana RM, Trijoko, Pratiwi R. 2014. Keragaman ikan anggota ordo perciformes di Sungai Sukamade Taman Nasional Meru Betiri. *Biomedika* 7 (2): 46–52. [Indonesian]
- Sahami FM, Kepel RC, Olii AH, Pratasik SB. 2019a. Determination of morphological alteration based on molecular analysis and melanophore pattern of the migrating Nike fish in Gorontalo Bay, Indonesia. *AAAL Bioflux* 12 (4): 1358–1365.
- Sahami FM, Kepel RC, Olii AH, Pratasik SB. 2019b. What species make up the Nike fish assemblages at the macrotidal estuary in Gorontalo Bay, Indonesia? [version 1; peer review: 2 approved with reservation]. *F1000Research* 8: 1654.
- Salam A, Sahami FM, Panigoro C. 2016. Nike (*Awaous melanocephalus*) fishery and mercury contamination in the estuary of Bone-Bolango River. *Omni-Akuatika* 12 (2): 130–136.
- Sara L, Muskita WH, Astuti O, Safilu. [2016](#). The reproductive biology of blue swimming crab *Portunus pelagicus* in Southeast Sulawesi Waters, Indonesia. *AAAL Bioflux* 9 (5): 1101–1112.
- Strüder-Kypke M, Lynn DH. 2010. Comparative analysis of the mitochondrial cytochrome c oxidase subunit I (COI) gene in ciliates (Alveolata, Ciliophora) and evaluation of its suitability as a biodiversity marker. *System Biodivers* 8 (1): 131–148.
- Taillebois L, Maeda K, Vigne S, Keith P. 2012. Pelagic larval duration of three amphidromous Sicydiinae gobies (Teleostei: Gobiidae) including widespread and endemic species. *Ecol Freshw Fish* 21 (4): 1–8.
- Taillebois L, Castelin M, Lord C, Chaharria R, Dettai A, Keith P. 2014. New sicydiinae phylogeny (Teleostei: Gobiidae) inferred from mitochondrial and nuclear genes: insights on systematics and ancestral areas. *Mol Phylogenet and Evol* 70: 260–271.
- Teletchea F. 2009. Molecular identification methods of fish species: reassessment and possible applications. *Rev Fish Biol Fish* 19: 265–293.
- [Tjakrawidjaja AH. 2002. Jenis ikan air tawar dari Manggarai, Flores, dengan variasi aspek limnologinya. J Iktiologi Indones 2 \(2\): 15–22.](#)
- Thacker CE, Roje DM. 2011. Phylogeny of Gobiidae and identification of gobioid lineages. *System Biodivers* 9 (4): 329–347.
- Thomas Jr RC, Beldia III PD, Campos WL, Santos MD. 2013. Resolving the identity of larval fishes, Dulong, in the Verde Island Passages, Philippines. *Phil J of Nat* 18: 29–36.
- [Tjakrawidjaja AH. 2002. Jenis ikan air tawar dari Manggarai, Flores, dengan variasi aspek limnologinya. J Iktiologi Indones 2 \(2\): 15–22.](#)
- Usman MY. 2016. Analisis Variasi Genetik Ikan Penja Indigenous Perairan Polewali Mandar Sulawesi Barat dan Ikan Nike (*Awaous* sp.) Indigenous Perairan Gorontalo. [Thesis]. UIN Alauddin Makassar, Makassar. [Indonesian]
- Valade P, Lord C, Grondin H, Bosc P, Taillebois L, Iida M, Tsukamoto K, Keith P. 2009. Early life history and description of larval stages of an amphidromous goby, *Sicyopterus lagocephalus* (Gobiidae: Sicydiinae). *Cybius* 33(4): 309–319.
- Viswambharan D, Pavan-Kumar A, Singh DP, Jaiswar AK, Chakraborty SK, Nair JR, Lakra WS. 2013. DNA barcoding of gobiid fishes (Perciformes, Gobiidae). *Mitochondrial DNA* 26 (1): 15–19.
- Wang ZD, Liao J, Huang CQ, Long SS, Zhang S, Guo YS, Liu L, Liu CW. 2017. Significant genetic differentiation of *Gobiopterus lacustris*, a newly recorded transparent goby in China. *Mitochondrial DNA Part A*: 1–7.

- Watanabe S, Iida M, Hagihara S, Endo H, Matsuura K, Tsukamoto K. 2011. First collection of amphidromous goby post-larvae of *Sicyopterus japonicus* in the ocean off Shikoku, Japan. *Cybium* 35 (4): 371–379.
- Watson RE. 2008. A new species of *Stiphodon* from southern Sumatra (Pisces: Gobioidae: Sicydiinae). *Zootaxa* 1715: 43–56.
- Yamasaki N, Kondo M, Maeda K, Tachihara K. 2011. Reproductive biology of three amphidromous gobies, *Sicyopterus japonicus*, *Awaous melanocephalus*, and *Stenogobius* sp., on Okinawa Island. *Cybium* 35 (4): 345–360.